



ETP 41

(EXTERNAL TECHNICAL PAPER NUMBER 41)

Attributes of the Tappex Hand Installation Tool for use with Self Tapping Inserts

UK Patent Application Number GB0903602.1

- Extended nose to help where access is restricted.
- Metric hexagon drive for use with socket drive tools.
- Centred to aid alignment with pillar drill or mill.
- Alignment bush retained by O ring.
- May be used with tap wrench.
- Nose designed to install the insert to the correct depth.





INSERT INSTALLATION PROCEDURE – (No Warranty Claims Considered Unless Followed)

- 1) Prepare the hole in the parent material to Tappex recommended dimensions.
- 2) Mount the Hand Tool in a suitable socket to be driven by screwdriver handle, tommy bar, tap wrench or fixed drill chuck.
- 3) Screw the insert onto the thread portion of the installation tool. Ensure the cutting features of the insert are pointing away from the hand tool if the insert is not double ended.
- 4) Place the insert into the recommended counter-bore / counter-sink at the top of the hole, and ensure the installation tool is perpendicular to the hole axis. (To assist the Tappex Hand Tool comes complete with an alignment bush. If there is a space restriction, initially locate in a stationary fixed drill chuck or centre and turn by hand.)
- 5) Turn the installation tool 'clockwise' to allow the insert to cut into the parent material and into the hole whilst ensuring that the tool remains perpendicular to the hole axis (hold the alignment bush firmly against the surface of the parent material). The spigot on the end of the hand tool ensures that the insert is installed correctly to a depth of 0.1 to 0.2mm sub flush when the face of the Hand Tool Nose contacts the surface of the material.
- 6) Release the installation tool from the insert by sliding the alignment bush up the shank, engaging a spanner in the flats on the Hand Tool Nose and prevent from rotating, while turning the installation tool in an 'anti-clockwise' direction.
- 7) Unwind the installation tool completely from the insert and the insert will remain installed securely in the parent material.



ADDITIONAL NOTES

When being used to install short length asymmetrical inserts, the threaded section of the hand installation tool should be ground down to less than the insert slot depth/hole position.

For particularly arduous metal applications, a suitable cutting lubricant/tapping compound may be necessary and the use of safety glasses is advised.

M2/M2.5 hand tools are only suitable for low-strength materials, as the shear resistance of the studs may be insufficient.

Under certain circumstances it may be possible to drive the hand tool with an electric screwdriver with torque limiting clutch.

The Alignment Bush is not hardened and may be machined to allow its use in mould corners or where access is restricted or bored out to allow headed inserts to be installed.

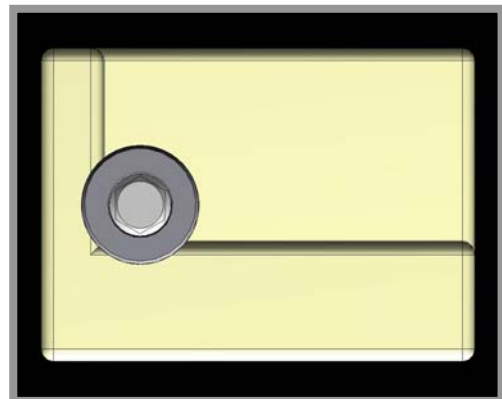
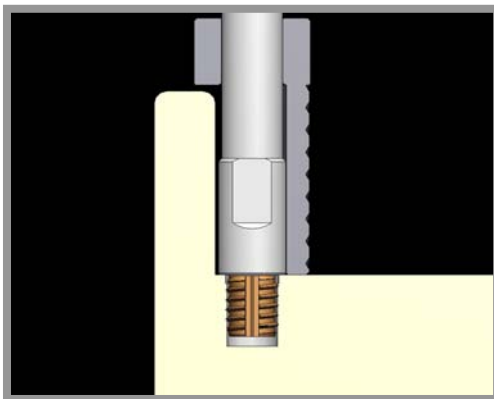

MAXIMUM INSTALLATION TOOL TORQUES – Nm

(ALIGNMENT BUSH BORE/OUTSIDE DIAMETERS – mm)

M2	=	1.0	(7.2/9)	M5	=	10.0	(10.7/17)
M2.5	=	1.5	(7.2/11)	M6	=	16.0	(11.2/19)
M3	=	2.5	(7.2/11)	M8	=	28.0	(14.2/22)
M3.5	=	3.2	(7.7/12)	M10	=	40.0	(19.2/25.4)
M4	=	5.5	(8.7/14)	M12	=	60.0	(-/-)

When ordering Hand Tool Assembly, specify Part No. 031 + Thread Size of Insert – i.e. 031M6

Issue 2 – 09-06-10

Engineering Department